

# Zildjian® DRUM SET METHOD



BY **MARK WESSELS**  
WITH VIDEO LESSONS FROM  
**WAYNE SALZMANN II**

**INCLUDING FREE video lessons**  
Available at [www.zildjian.com/education](http://www.zildjian.com/education)

# INTRODUCTION

There are countless books, websites, apps, videos and social channels all devoted to teaching you how to play drums. With a pretty broad range in quality and depth of lesson content, we wanted to take a slightly different approach. Our goal for this Drum Method project isn't to replace the thousands of other resources available. It's to **INSPIRE PEOPLE TO EXPRESS THEMSELVES THROUGH MUSIC** by providing trusted, guided lessons, and a motivating experience that helps get your feet wet with music and percussion. As the global leaders in cymbals, drumsticks, and mallets, we at the Avedis Zildjian Company are committed to helping create the next generation of musicians, artists, and/or music lovers.

For every student who fully commits to buying a drum set and signing up for lessons, there are countless other people who are interested in the drums, but either don't know where to start or aren't sure if they're ready to jump in head-first. That's where the Zildjian Drum Set Method comes in. Start with the first lesson - you don't need drums or sticks to get started, and it's totally free.

If your dream is to one day play in a band, or even to become a 'good enough' drummer to be able to play along with your favorite tunes, then we **HIGHLY RECOMMEND** that you take lessons from a qualified drum teacher.

For the drum teachers out there, we think you're going to love having this resource available. In the planning and production of this series, we wanted to give the student a rock-solid drumming foundation and well-rounded knowledge, delivered in a fast-paced, user friendly environment. We hope you'll consider incorporating it into your current curriculum.

**READY TO GET STARTED?** We hope you enjoy using this book & video series, joining a growing community of music-makers with every step, and maybe even joining the Zildjian family in the future!

# ABOUT US

## THE AVEDIS ZILDJIAN COMPANY



### THE WORLD'S LEADING MAKER OF CYMBALS, DRUMSTICKS, AND MALLETS

The Zildjian Company has been synonymous with setting the standard for the development and manufacture of high performance musical instruments since 1623. As the world's leading maker of cymbals, drumsticks, and percussion mallets, Zildjian products are sold across the globe, under the Zildjian®, Vic Firth®, and Balter™ brands, and are the standard to which all other cymbals, drumsticks and mallets are measured. From the beginner to the world's greatest rock stars, jazz performers and concert percussionists, amateurs and pros alike choose Zildjian, Vic Firth, and Balter products to allow them to experience and share the joy of music.

Headquartered in Norwell, Massachusetts with offices in Newport, ME, Los Angeles, CA, London, UK, and Singapore, Zildjian products are sold globally through distributors and via a network of dealers. All Zildjian instruments are made in the USA at our cymbal factory in Norwell, MA and drumstick/mallet factory in Newport, ME.

The Zildjian logo is rendered in a highly stylized, cursive script. The letters are thick and black, with a small registered trademark symbol (®) at the end of the word. The 'Z' is particularly large and ornate, with a long, sweeping tail that extends under the 'i'.

[WWW.ZILDJIAN.COM](http://WWW.ZILDJIAN.COM)

## MARK WESSELS

DIRECTOR OF EDUCATION • ZILDJIAN® | VIC FIRTH® | BALTER MALLETS™

*Author of the "Zildjian Drum Set Method"*

Mark Wessels is an internationally respected author and educator. As a publisher, his "Fresh Approach" method books are among the most successful in the world, with over 300,000 copies in print.

From 1983-2000, Mark taught percussion in some of the most successful public school programs in Texas and launched one of the first internet sites devoted to percussion education. As a result, he was hired as the "Director of Internet Activities" in 2000 for the Vic Firth Company and built one of the most popular online destinations for drummers today. Through the years at Vic Firth, Mark created the vast library of educational resources, many of which were ground breaking in its day. From Essential Rudiments, Groove Essentials and other popular posters to video lessons, play-along tracks, "In the Lot" and "Learn the Music" videos, Mark has been at the forefront of percussion education for over two decades.

During his tenure at Zildjian, Mark has also been responsible for producing thousands of drum set, marching and concert performance videos from all over the world. Working with other dedicated members of the Zildjian team, he also produced and directed the popular "Zildjian Underground," "Zildjian Live" and "vfJAMS" video series. Outside of his work at Zildjian, Mark continues to publish new projects through his website at [WWW.MWPUBLICATIONS.COM](http://WWW.MWPUBLICATIONS.COM).



## WAYNE SALZMANN II

*Host of the "Zildjian Drum Set Method" Video Lesson Series*

Wayne Salzmann II is a drummer, educator, author, and composer based in Austin, Texas. He has been the Drum Set Instructor at the University of Texas at Austin for over a decade and has given clinics and masterclasses worldwide.

In addition to his extensive touring and recording with Grammy winning guitar virtuoso Eric Johnson and iconic songwriter Bob Schneider, Salzmann has also performed and/or recorded with Steve Miller, Kenny Rogers, Kris Kristofferson, Christopher Cross, Joe Satriani, Mike Stern, Robben Ford, Chris Potter, Dick Oatts, Bill Watrous, Diane Schuur, Bobby Shew, UT Jazz Faculty,

San Antonio Symphony, and many others. He has hundreds of recording credits, including a Billboard no. 1 Jazz record, a Billboard no. 1 Blues record, and feature film soundtracks.

Wayne's book "Developing Melodic Language on the Drums" has received high acclaim from legendary drummers Peter Erskine, Ed Soph, Carl Allen, John Riley, and from *Modern Drummer Magazine*. He currently serves as a member of the Drum Set Committee for the Percussive Arts Society, and is an artist/clinician for DW Drums, Pedals, & Hardware, Zildjian Cymbals, Remo Drumheads, and Vic Firth Drumsticks. Keep up with Wayne at [WWW.WAYNESALZMANN.COM](http://WWW.WAYNESALZMANN.COM).

# TABLE OF CONTENTS

INTRODUCTION .....	2 – 7	LESSON THIRTEEN .....	32 – 33
LESSON ONE.....	8 – 9	The Ride Cymbal, Ride Cymbal Position, French Grip, Ride Cymbal Grooves, Quarter Note Ride Patterns, Adding the Hi-Hat 'Chick'	
LESSON TWO .....	10 – 11	LESSON FOURTEEN .....	34 – 35
Learn About Drum Sticks		Music Reading Exercises, Independence Exercises, The Toms, Moving Around the Toms	
LESSON THREE .....	12 – 13	LESSON FIFTEEN .....	36 – 37
Gripping the Sticks, Adjusting the Throne and Practice Pad Height		Grooves Utilizing the Toms, Hearing Protection, 16th Notes, 16th Note Drum Fills	
LESSON FOUR.....	14 – 15	LESSON SIXTEEN .....	38 – 39
The Rebound Stroke, Essential Rudiment: Single Stroke Roll		Open Hi-Hat Sizzle Sound, Open Hi-Hat Exercises, Open Hi-Hat Combos, Half-open Hi-Hat, Open Hi-Hat Sounds within Ride Patterns	
LESSON FIVE .....	16 – 17	LESSON SEVENTEEN .....	40 – 41
Learn about the Snare Stand and Snare Drum Anatomy		Stroke Styles: Down/Tap/Up, Accent Patterns, 8th Rests, Fills Using the 8th Rest	
LESSON SIX.....	18 – 19	LESSON EIGHTEEN .....	42 – 43
Bass Drum Pedal, Bass Drum Anatomy, Pedal Technique		Syncopated Left Hand 16ths, Multiple Bounce Roll, Drag	
LESSON SEVEN .....	20 – 21	LESSON NINETEEN .....	44 – 45
Hi-Hat Stand, Sticks on the Hi-Hat, Beginning Independence, "Rock Star" Play-along Track		Syncopated Bass Drum 16ths, Stick Bag, Rim-shot, Syncopated Bass Drum Combos	
LESSON EIGHT.....	22 – 23	LESSON TWENTY.....	46 – 47
Playing the Hi-Hat Pedal, Double Stroke Roll, Single Paradiddle, Sticking Patterns		16th Note Ride Pattern, One- Handed and Alternating, Verse/Chorus Musical Song Form	
LESSON NINE.....	24 – 25	GROOVE LIBRARY.....	48 – 55
Music Notation Basics, Music Reading Exercises, 8th Notes		Quarter Note, 8th Note Ride Pattern (48) Syncopated 8th Note Grooves (49) Quarter Note Ride with BD/SN 8ths (50) Grooves Utilizing the Toms (50) Open Hi-Hat Sizzles/8th Note Ride (51) Syncopated Left Hand 16ths (52) Syncopated Bass Drum 16ths (53) 16th Note Ride - One Handed (54) 16th Note Ride - Alternating (55)	
LESSON TEN.....	26 – 27		
8th Note Grooves, Accent, Cross- Stick, 8th Note "Combos"			
LESSON ELEVEN .....	28 – 29		
Zildjian Family Story, Anatomy of a Cymbal, Cymbal Set-up, Crash Cymbal Stroke, Musical Phrases			
LESSON TWELVE.....	30 – 31		
Drum Fills, The Flam, Playing Fills Within a Musical Phrase			

# HOW TO USE THIS BOOK

Fundamentally, there is no “right” or “wrong” way to approach any book, but here are a few suggestions that might help you get the most out of the Zildjian Drum Set Method.

If you’re a first-day beginner, you’ll obviously want to start at the beginning and progress through each lesson in succession. This method introduces skills that build from one to the next. If you’ve been playing a while, we recommend that you skim through the first part of the book to make sure you understand the concepts and can play all of the material included in each of the lessons.

In addition to learning the fundamentals of how to play the drums, this book also includes a significant amount of information about the gear you’ll be using – necessary info which is often omitted from other beginner drum methods. We believe that knowing how each piece of gear functions and how to fine tune your setup is an important part of learning about the drums.

Unless you’re studying privately with a qualified drum instructor, the free VIDEO LESSONS available on zildjian.com are a crucial part of this method. In the videos, Wayne Salzman takes you step-by-step through each lesson, introducing concepts and demonstrating the fundamentals of each new technique, groove and fill. We encourage you to pick up your sticks and play along instead of simply watching the videos.



At the top of each lesson you can scan a QR CODE with a mobile device that will take you directly to the content available on the Zildjian website. Be sure to take advantage of the resources available. The content includes video lessons, play-along tracks and extended educational material that we were not able to fit in the pages of this book. If you wish to view the website on a desktop or laptop computer, bookmark the address for the full lesson series:

**[www.zildjian.com/education/zildjian-drum-set-method.html](http://www.zildjian.com/education/zildjian-drum-set-method.html)**

We’ll leave you with one final thought. The key to becoming successful is to ALWAYS HAVE FUN! As with any worthwhile endeavor, there may be times when you become frustrated. We encourage you to take a step away from the book during each practice session and play along to some of your favorite tunes. Not only will you have fun, but by using your ears and listening to music created with professional drummers, you’ll develop a sense of how to create parts that serve the music – which is the true role of all great drummers.

Good luck on your journey!



## THE HI-HAT

Another complex piece of gear on the drum set is the hi-hat stand. Be sure to watch the video to learn how to setup and adjust the hi-hat before you begin to play the exercises on this lesson.

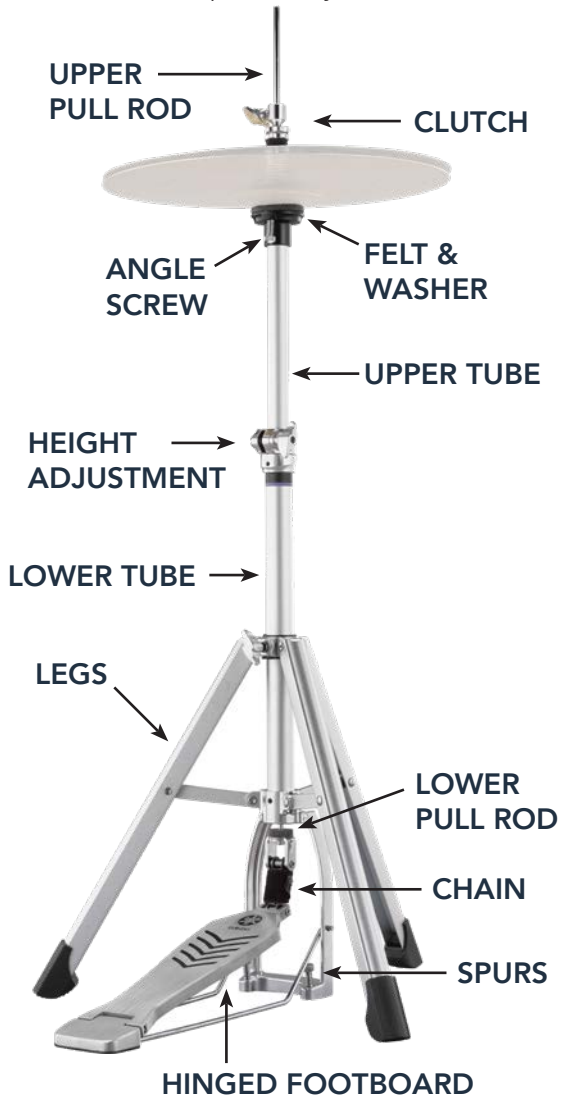

### HI-HAT STAND ANATOMY

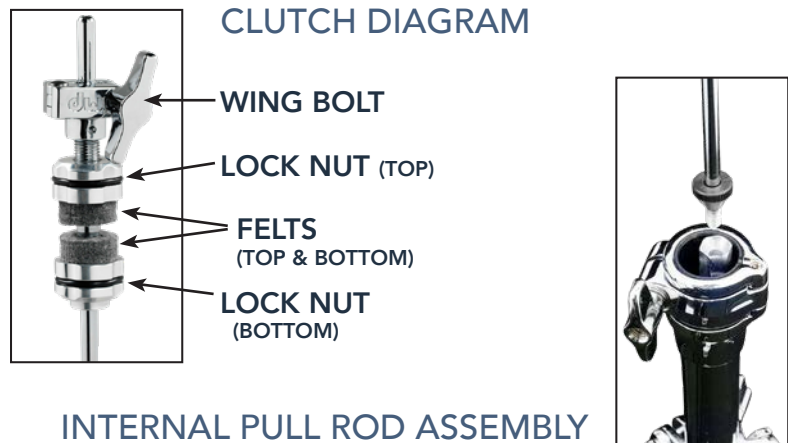

### HI-HAT SETUP

Position the hi-hat pedal at the spot where your foot naturally falls. The height of the cymbals is a matter of personal taste and playing style, but you'll need to easily play with the tip of the stick on the top of the cymbal and the shoulder of the stick on the edge.



### HI-HAT CYMBAL SELECTION

For most of today's popular music, the pair of hi-hat cymbals are arguably the most important cymbals on the kit. While there are many models of cymbals, all with their own unique sound characteristics, Zildjian's 14" New Beat Hi-Hats are considered the most versatile in the world today.

If you're looking for practice options, the L80 Low Volume cymbals are 80% quieter than traditional cymbals.



Did you know that the “hi-hat” stand developed from a device known as the “lowboy”? To learn about how this unique instrument evolved, check out “A Century of Drum Set Evolution” series at [www.vicfirth.com/education](http://www.vicfirth.com/education).

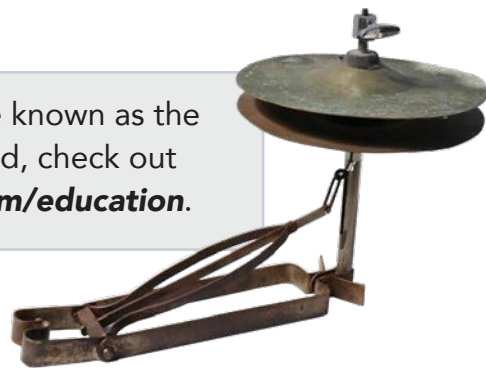

## PLAYING THE STICKS ON THE HI-HAT

Most drummers play “right-over-left” on hi-hat/snare patterns, although playing the left hand on the hi-hat (called the “open hand position”) offers many advantages as well. While pressing the hi-hat pedal down with the foot, experiment with playing steady rebound strokes on the right and left hands. You may wish to turn your hand slightly to the “French Grip” position to make the stroke easier (especially on the left).

## BEGINNING INDEPENDENCE

In these exercises, you’ll play steady hi-hat strokes with one hand and add snare (with the opposite hand) and bass drum. Strive to keep the motion of the hi-hat strokes smooth and consistent.

<b>1</b>	<b>2</b>	<b>3</b>	<b>4</b>
HH X X X X	HH X X X X	HH X X X X	HH X X X X
SN ●	SN	SN ● ● ●	SN
BD	BD ●	BD	BD ● ● ●

These next exercises work great as new drum beats. Play each exercise *separately* along with some music until it feels comfortable then mix-and-match exercises to come up with even more variations.

<b>5</b>	<b>6</b>	<b>7</b>	<b>8</b>
HH X X X X	HH X X X X	HH X X X X	HH X X X X
SN	SN	SN ●	SN ●
BD ●	BD ● ●	BD ●	BD ● ● ●

### “ROCK STAR” PLAY-ALONG TRACK

Our first play-along track utilizes this drum beat, which we call “four on the floor” (because it has bass drum notes on all four beats). Practice this groove with a metronome until you can play in perfect time.

HH X X X X
SN ● ●
BD ● ● ● ●

On the [zildjian.com](http://zildjian.com) lesson page, you can download two versions of this track. The first has a built-in “click” that can help you maintain a steady tempo. The second version has NO click, which makes playing along a real challenge. Use your ears and listen to the other musicians to stay in time.